

INSTRUCTION MANUAL FOR THE LP SERIES LABEL PASTER

Check Machine carefully to insure that nothing was loosened or damaged in transit.

The operating instructions should be read before operating the machine.

Pro Pack Solutions, Inc.

(770) 554-1187
(877) 776-7225

CAUTION

NEVER PERFORM MAINTENANCE OR CLEANING WHILE MACHINE IS IN OPERATION. KEEP HAIR AWAY FROM ROLLERS AND NEVER USE A CLOTH NEAR ROLLERS WHILE MACHINE IS IN OPERATION. ALWAYS TURN POWER SWITCH TO OFF POSITION AND REMOVE PLUG FROM POWER SOURCE. FAILURE TO DO SO COULD CAUSE ELECTRICAL SHOCK OR INJURY.

Pro Pack Solutions, Inc.

(770) 554-1187
(877) 776-7225

OPERATING INSTRUCTIONS FOR INITIAL START UP AND OPERATION OF THE LP SERIES LABEL PASTER.

Remove machine from carton.

Remove packing carefully around pick-off fingers to avoid injury and spread fingers evenly along roller face.

Check that a 115v power source is available.

Remove feed table and inspect glue pan to see that it is free from dust or foreign matter. Fill glue pan with adhesive that is suitable for your work. Fill to approximately $\frac{1}{4}$ " below cut outs on sides of glue pan. Do not overfill.

Replace feed table and check to see that the guard is in a down and running position with power switch in off position. Now plug machine cord set into power source and turn main power switch on.

Let machine run for a minute. Check adhesive level.

The coating thickness is controlled by turning the metering knob. This knob is located on the left side of the coating head.

The metering knob has numbers from 0 to 8 within a 180° range. The lower the number at the point of register the thinner the coating of adhesive on the coating roller. The higher the number would result in more adhesive on the coating roller.

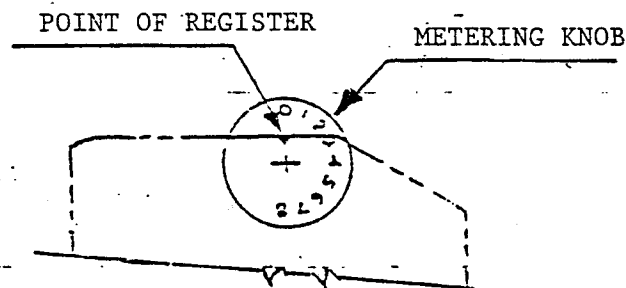

It is important to note that the machine should not be run without adhesive or damage could occur to the coating roller.

Do not stop the machine with adhesive in it for a long period of time. The adhesive will harden on the glue roller and scrapers and make cleaning difficult.

GENERAL INSTRUCTIONS

LUBRICATION

To keep your machine running quietly and efficiently oil with a light machine oil (#30 weight). One or two drops is all that is needed. This should be done after cleaning or when required.

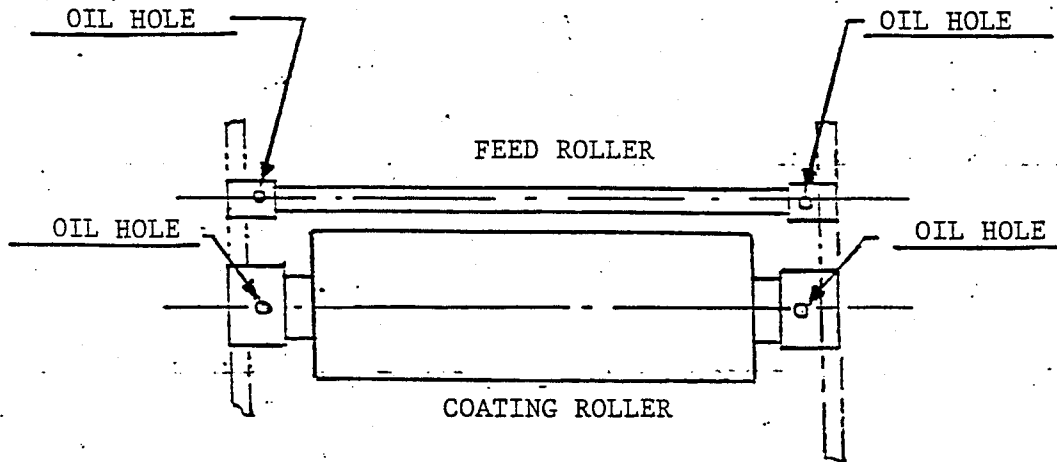

Occasionally a light grease lubricant should be applied sparingly to the drive gears (such as a "Keystone 5P7").

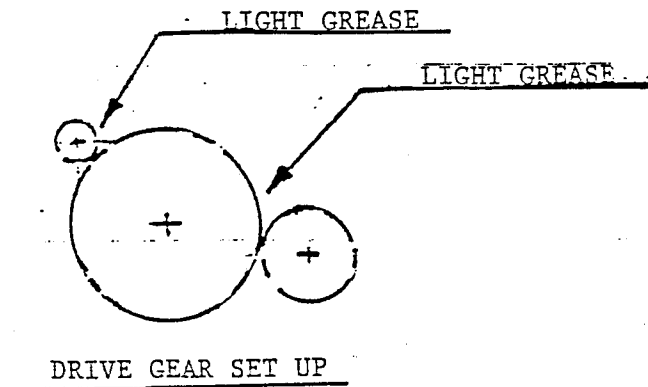

Pro Pack Solutions, Inc.

(770) 554-1187
(877) 776-7225

Instructions for removing and replacing of coating head from machine base.

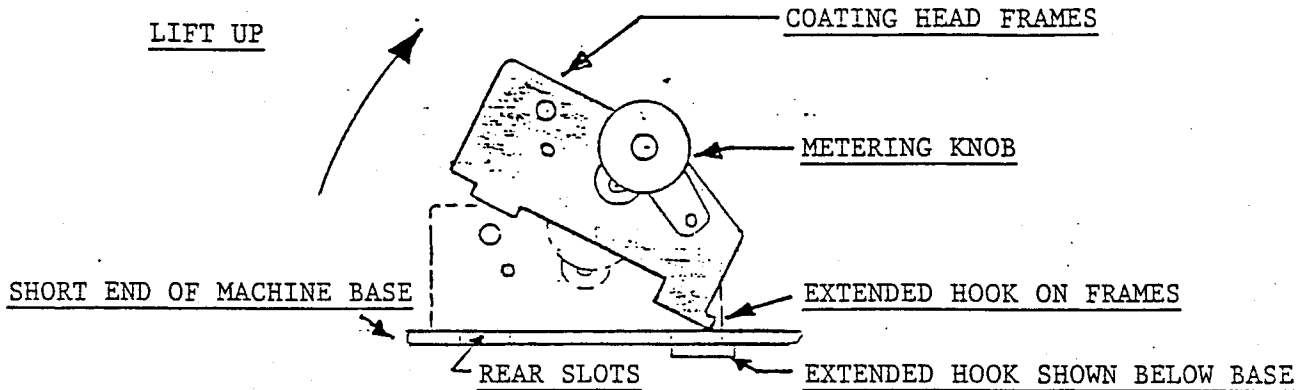

To Remove:

1. Turn power switch to off position.
2. Remove power cord from outlet.
3. Lift cover ass'y up to open position.
4. Lift feed table up and remove.
5. Lift rear of coating head frame up and pivot it away from rear slots.
6. Lift up and away.

To Replace:

1. With front of coating head frame with extended hook above front slots insert in and catch under machine base.
2. Pivot coating head frame down and into rear slots .
3. Replace feed table.

Pro Pack Solutions, Inc.

(770) 554-1187
(877) 776-7225

INSTRUCTIONS FOR CLEANING & MAINTENANCE OF THE
LP SERIES LABEL PASTER

MAINTENANCE:

Before starting up machine after cleaning it is necessary to lubricate the roller bearings, "refer to general instructions for lubricating of bearings."

CLEANING APPLICATION:

After the gluing application is completed for the day the glue pan should be removed, emptied of remaining adhesive and cleaned with water. Remove the coating head and also clean with water, wipe off excess water with a clean dry cloth.

When the label paster is not in use for a period of time it is suggested to wipe clean the excess adhesive that might have accumulated under the scraper, on sides of coating roller and in the glue pan. Keep the machine as clean as possible for best performance.

Finger blades should be handled carefully to avoid injury or cause damage to the finger blades. Keep clean and free from adhesive when the fingers become worn or disfigured replacement is suggested.

Pro Pack Solutions, Inc.

(770) 554-1187
(877) 776-7225

INSTRUCTIONS FOR UNEVEN COATING

Uneven coating on the glue roller could indicate that the scraper blade is out of adjustment. To adjust the scraper blade do the following:

1. Shut off the motor and remove plug from power source.
2. Turn coating dial to zero.
3. Check that the setscrew holding the yoke to the scraper bridge pin is tight.
4. Remove feed table.
5. Loosen scraper blade screws and remove scraper.
6. Inspect scraper blade to see if it is in good condition, no damage to the blade.
7. Reattach scraper blade the same way it was removed. (Short side facing glue roller.)
8. Snug up on screws and insert shims between blade and glue roll. (Shim stock of .001 is recommended.)
9. Tighten screws. (Remove shims.)
10. The gap between scraper and glue roll will now be even.

Pro Pack Solutions, Inc.

(770) 554-1187
(877) 776-7225

GENERAL TOOLS FOR REPAIR & MAINTENANCE OF THE LP SERIES LABEL PASTER

NOMINAL HEX KEY SIZES (ALLEN WRENCH)

1/16, 5/64, 3/32, 1/8, 5/32

OPTIONAL

.001" SHIM STOCK OR PIECE OF BOND PAPER
(3) PIECES APPROXIMATELY 4" LONG

Pro Pack Solutions, Inc.

(770) 554-1187
(877) 776-7225

CONNECTING DIAGRAM FOR MOTOR WITH ON/OFF SWITCH FOR
LP SERIES LABEL PASTER

