

THE LEADER IN ADHESIVE COATING MACHINES IS THE **POTDEVIN NTZ** FOR PRECISE COATING ON MATERIALS UP TO 1/2" THICK

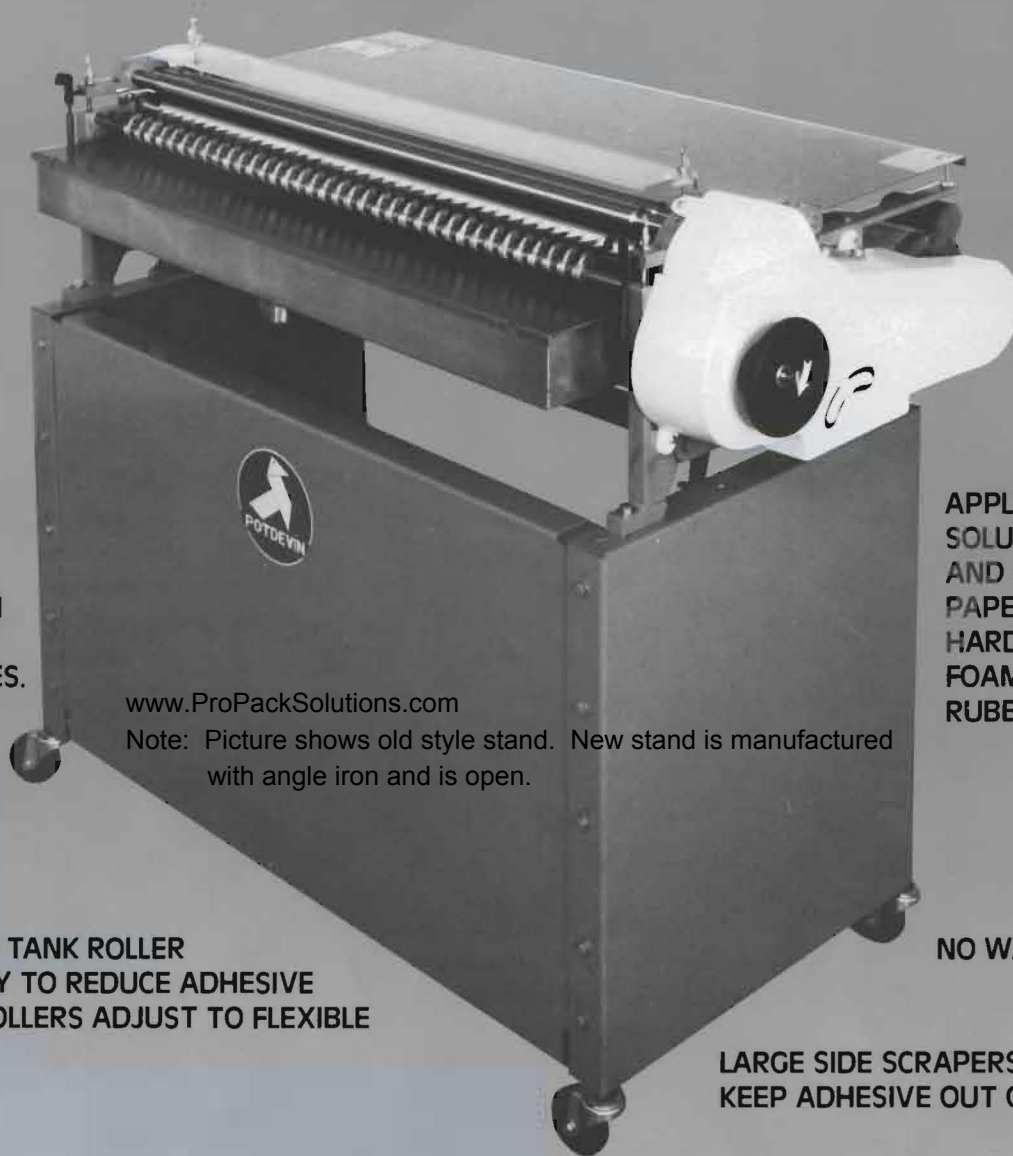

SMALL DIAMETER
COATING ROLLER
APPLIES UNIFORM
COATING TO BOTH
UNEVEN AND
SMOOTH SURFACES.

APPLY WATER
SOLUBLE ADHESIVES
AND COATINGS TO
PAPER, LEATHER,
HARDBOARD, PLASTIC,
FOAM, WOOD,
RUBBER & FABRIC.

www.ProPackSolutions.com

Note: Picture shows old style stand. New stand is manufactured
with angle iron and is open.

RUBBER COVERED TANK ROLLER
REVOLVES SLOWLY TO REDUCE ADHESIVE
FOAMING. FEED ROLLERS ADJUST TO FLEXIBLE
OR RIGID.

NO WASTE — NO MESS

LARGE SIDE SCRAPERS
KEEP ADHESIVE OUT OF BEARINGS.

YOU CAN PRODUCE COATED PARTS WITH THE POTDEVIN NTZ GLUER. THE
REGULATOR DIAL CONTROLS THE FILM THICKNESS OF THE ADHESIVE. JUST SET
DIAL FOR THE REQUIRED COATING THICKNESS. THE REMOVABLE ADHESIVE
TANK MEANS LESS CLEAN UP TIME.



Potdevin Machine Company

Pro Pack Solutions, Inc. (877) 776-7225
2421B Lance Court
Loganville, GA 30052



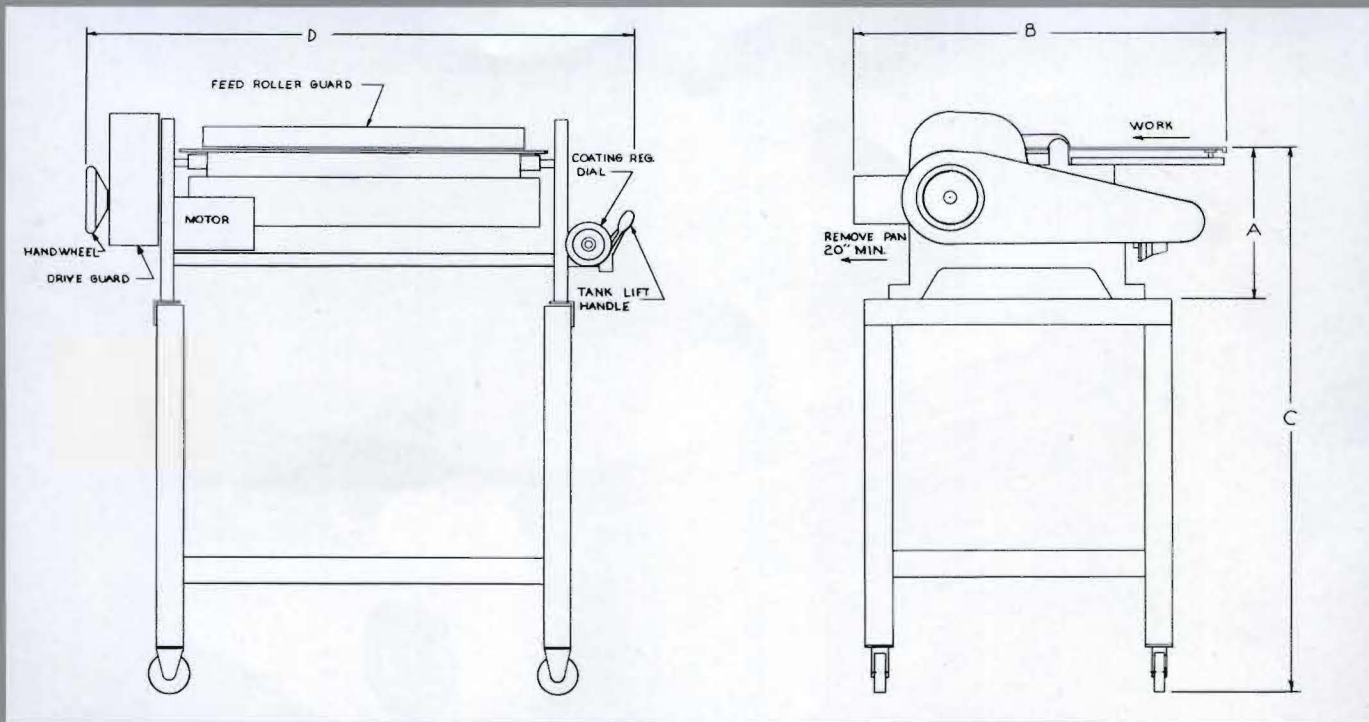

NTZ MACHINE SPECIFICATIONS

MODEL	ROLLER WIDTH INCHES	DIMENSIONS INCHES				TANK CAP QUARTS	NET WEIGHT POUNDS	GROSS WEIGHT POUNDS	STAND WEIGHT POUNDS
		A	B	C	D				
NTZ-27	27	12	25	41	43	11	200	250	60
NTZ-32	32	12	25	41	48	12	240	300	60
NTZ-36	36	12	25	41	52	13	280	340	65



Roller Arrangement (Flexible Material)

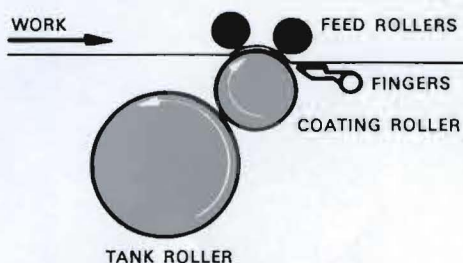

**COATING ROLLER SPEED 85 F.P.M.
MOTOR DRIVE**

1/3 hp 115 or 220 Volt, 60 Hz.,
1 phase AC Motor is standard.

**MOTORS WITH OTHER ELECTRICAL
CHARACTERISTICS ARE AVAILABLE
ON REQUEST**

Roller Arrangement (Rigid Material)

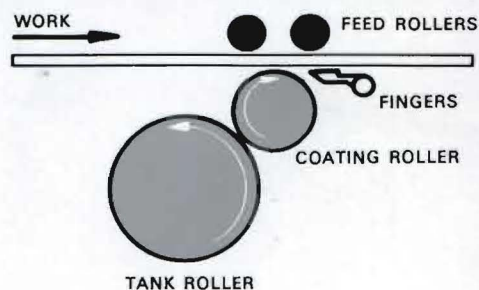

OPTIONAL ATTACHMENTS AVAILABLE

STAINLESS STEEL TANK ROLLER
EDGE AND STRIP GLUING ATTACHMENT
115 OR 220 Volt
VARIABLE SPEED DRIVE
PORTABLE FLOOR STAND
DELUXE FLOOR STAND AS SHOWN